



EV NEWS MONTHLY

Issue 34 - March 2025

By Jon Burdekin

Changes to tax / legislation

■ Driver training for heavier electric vans axed | PiVG extension confirmed

■ Plug-in van grant extended for another year

What EVs are there and what's coming?

Chinese entrants step up charge into UK EV market

FIAT Grande Panda EV joins the sub-£21k EV market

■ Volkswagen previews £17k entry-level electric car

DS No8 electric flagship on sale with up to 466 miles of range

New Volkswagen ID 2 electric car to cost less than £21k | What Car?

Websites / podcasts / reports to follow

■ 220250204 ECC January 2025.pdf
– very useful report by New Automotive

GREENFLEET 157 | GreenFleet

About our author: Jon Burdekin is a long-standing expert in this field, having worked for major leasing companies such as Alphabet GB Ltd and GE Capital Fleet Services. During his 15-year career with Alphabet, Jon held roles such as head of consulting services and head of product management. He also led the consultancy division, adding key value differentiation and driving technical innovation.

Jon has extensive knowledge in all aspects of fleet management and is a subject matter expert in the adoption of electric vehicles into company fleets. He also has deep expertise in the compliance risks associated with selling electric vehicles poorly.

Contact: jon@jbfleetconsulting.co.uk

Key: ■ Of particular interest

■ LCV specific

What EVs are there and what's coming?

 [Renault unveils new electric van line up](#)

 [China's Xpeng enters UK with electric SUV-coupe launch](#)

 [Farizon SV: pricing, payload and range](#)

[Toyota reveals model grades and equipment for all-electric Urban Cruiser](#)

 [NEW MODELS > Vans - EV Fleet World Issue 5 | 2024](#)

 [Kia reveals PV5 electric van exterior ahead of world premiere](#)

[First Renault 5 E-Tech electric superminis arrive in UK](#)

[435-mile range for new Volvo ES90](#)

 [Kia EV4 uncovered as electric saloon and hatch with up to 391-mile range](#)

[Kia sets stage for new small electric SUV with Concept EV2 unveiling](#)



Articles that may be of interest

[Watch The World's Fastest-Charging EV Hit 80% In 9 Minutes: 'Freaking Wild'](#)

[Chinese EV brands could tempt sceptic Europeans with just a 10% price reduction](#)

[Farage's anti-EV stance is boosting support for green vehicles, research suggests](#)

 [Price parity now commonplace on many used BEV and ICE cars](#)

[Electric vehicles increasingly 'normalised' but practical concerns linger](#)

 [Young drivers more attracted to Chinese EV brands than older peers | GreenFleet](#)

[EV transition helping with major skills and apprenticeship drive](#)

 [EV sales to overtake petrol by 2028, predicts Cox Automotive](#)

[Atilium reveals recycled EV batteries surpass virgin materials](#)

 [EV running costs '50% less' than equivalent ICE car](#)

 [Renault makes EV fire suppression tech open to all manufacturers | Autocar](#)

Key:  Of particular interest

 LCV specific

Articles that may be of interest

[New £5m UK battery plant to slash EV costs and production time](#)

[BP opens first dedicated EV charging and convenience hub](#)

[Used EV prices set to stabilise in 2025 as electric increases market share](#)

[Nine in 10 charge point hitches can be solved over the phone, AA finds](#)

EV NEWS MONTHLY - ISSUE 34 - MARCH 2025

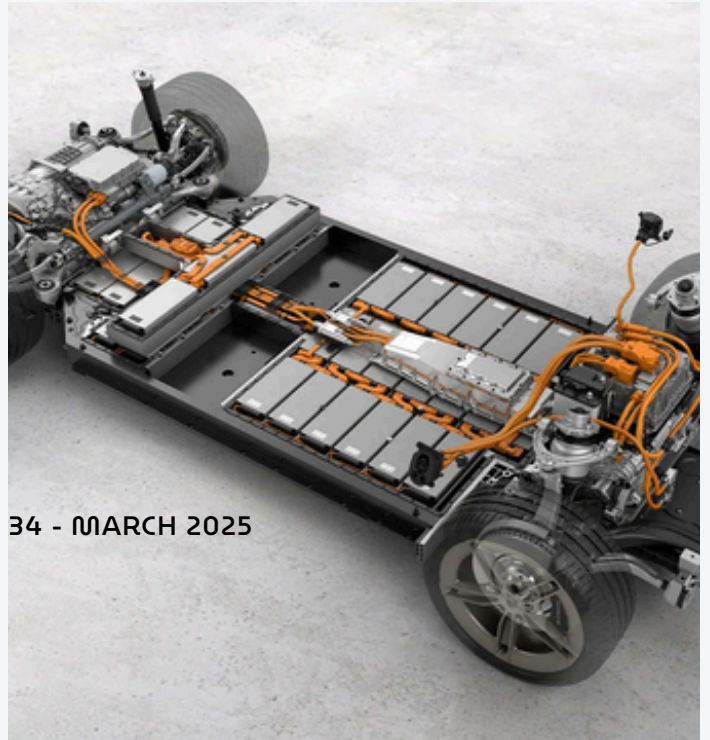

Key:  Of particular interest

 LCV specific